

SERIE 200 Il pieghevole semplice

SERIES 200 The simple folding door



Sistemi pieghevoli per mobili / Folding systems for furniture

KIT 0827-267

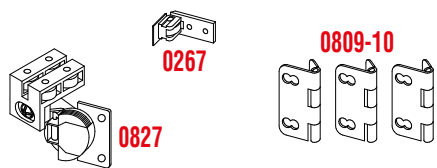

Legenda KIT / Kit Legend

0267	Rotella inferiore <i>Lower roller</i>
0809-10	Cerniera centrale simmetrica-asimmetrica con bussole <i>Symmetric-Asymmetric central hinge with bushes</i>
0827	Guida superiore ed inferiore con cerniera <i>Upper and lower runner with hinge</i>

Legenda altri componenti Legend other items

0823		Profilo alluminio superiore <i>Upper aluminium profile</i>
-------------	---	---

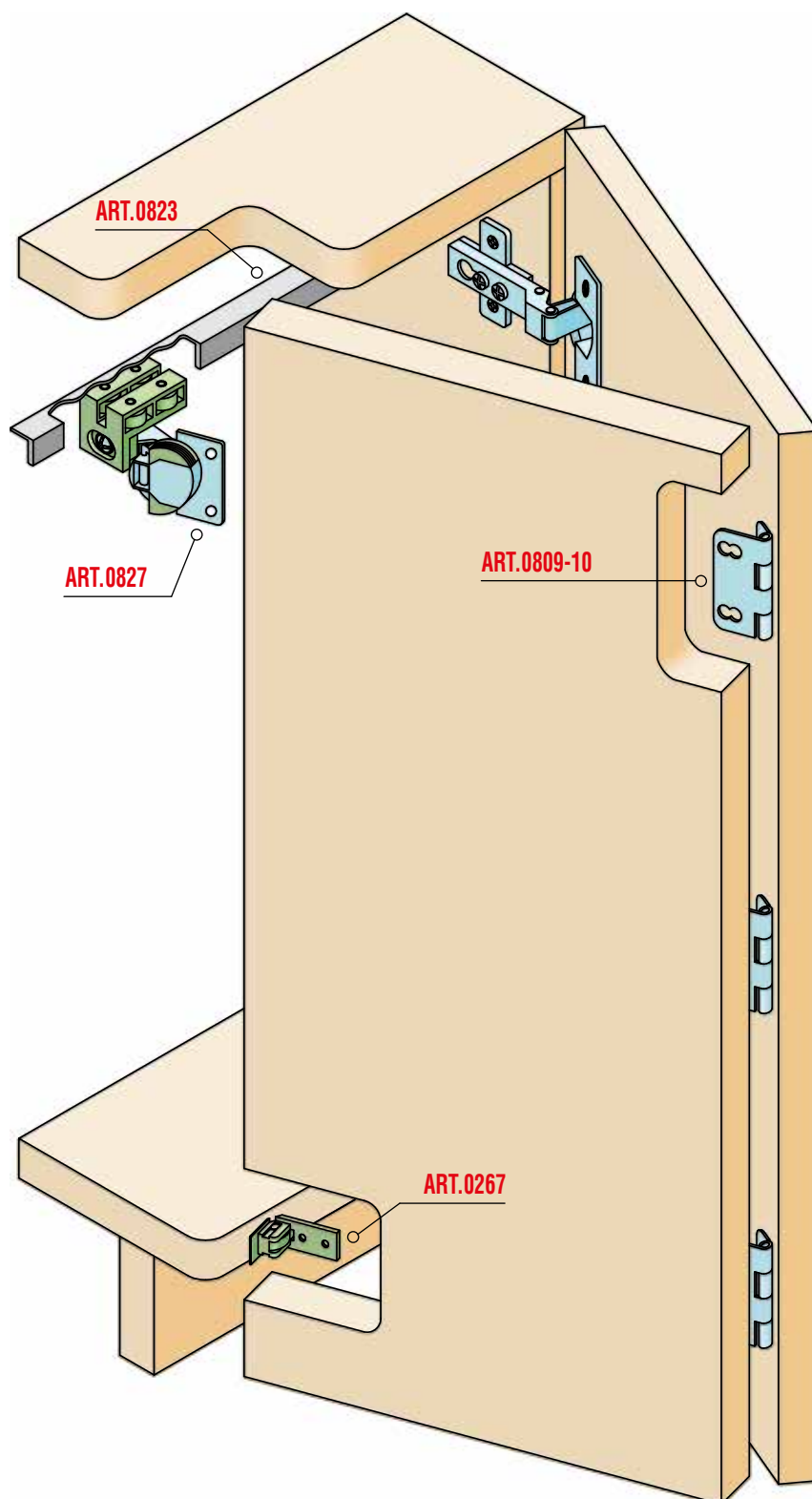



Sistemi scorrevoli per armadi / Folding systems for furniture

Sezione verticale / Vertical section

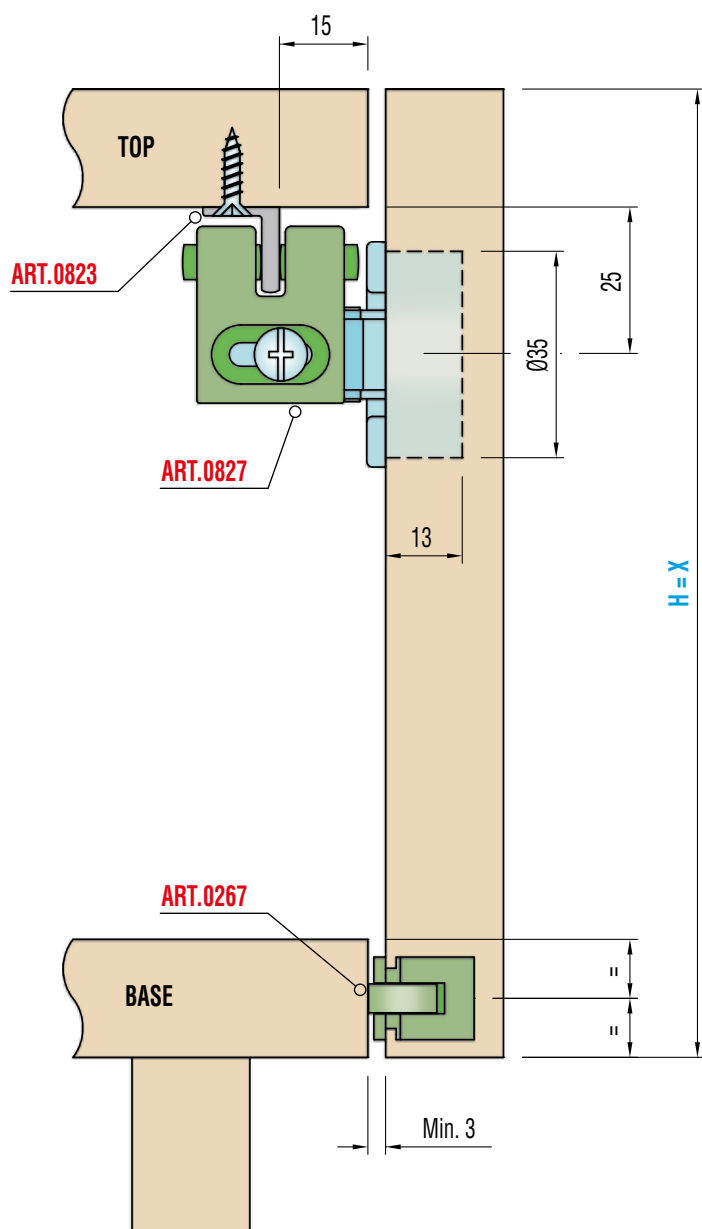

DIMENSIONI ANTE DIMENSIONS OF THE DOORS	
Altezza Height	max. 2600 mm.
Larghezza Width	max. 500 mm.
Spessore Thickness	min. 16 mm. - max. 30 mm.

Posizione di montaggio cerniere centrali art. 0809-10 Assembling position of the centre hinges art. 0809-10

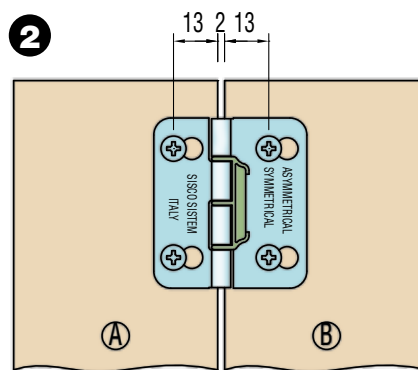
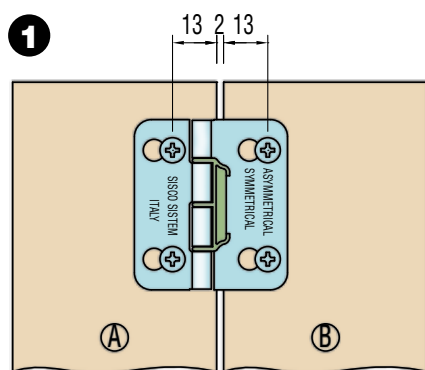

Per il corretto funzionamento del sistema, Vi consigliamo l'uso di cerniere laterali con apertura a 110°, in abbinamento alle cerniere centrali, ART.0809-10, montate in modo asimmetrico (1). Se invece utilizzate cerniere laterali con apertura a 90°, montate le cerniere centrali, ART.0809-10, in modo simmetrico (2).

To ensure a proper functioning of the system, we suggest you to use side hinges with 110° opening, along with centre hinges, ART.0809-10, asymmetrically fitted (1). If you use side hinges with 90° opening, fit centre hinges, ART.0809-10, symmetrically (2).

Schema foratura ante / Doors drilling

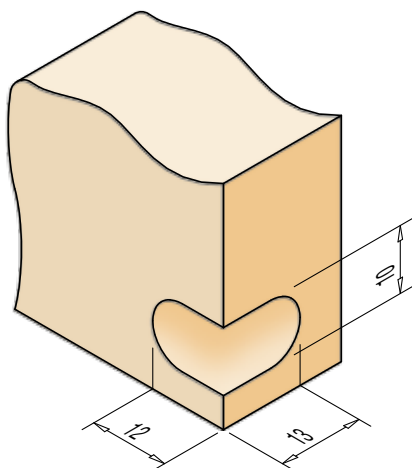
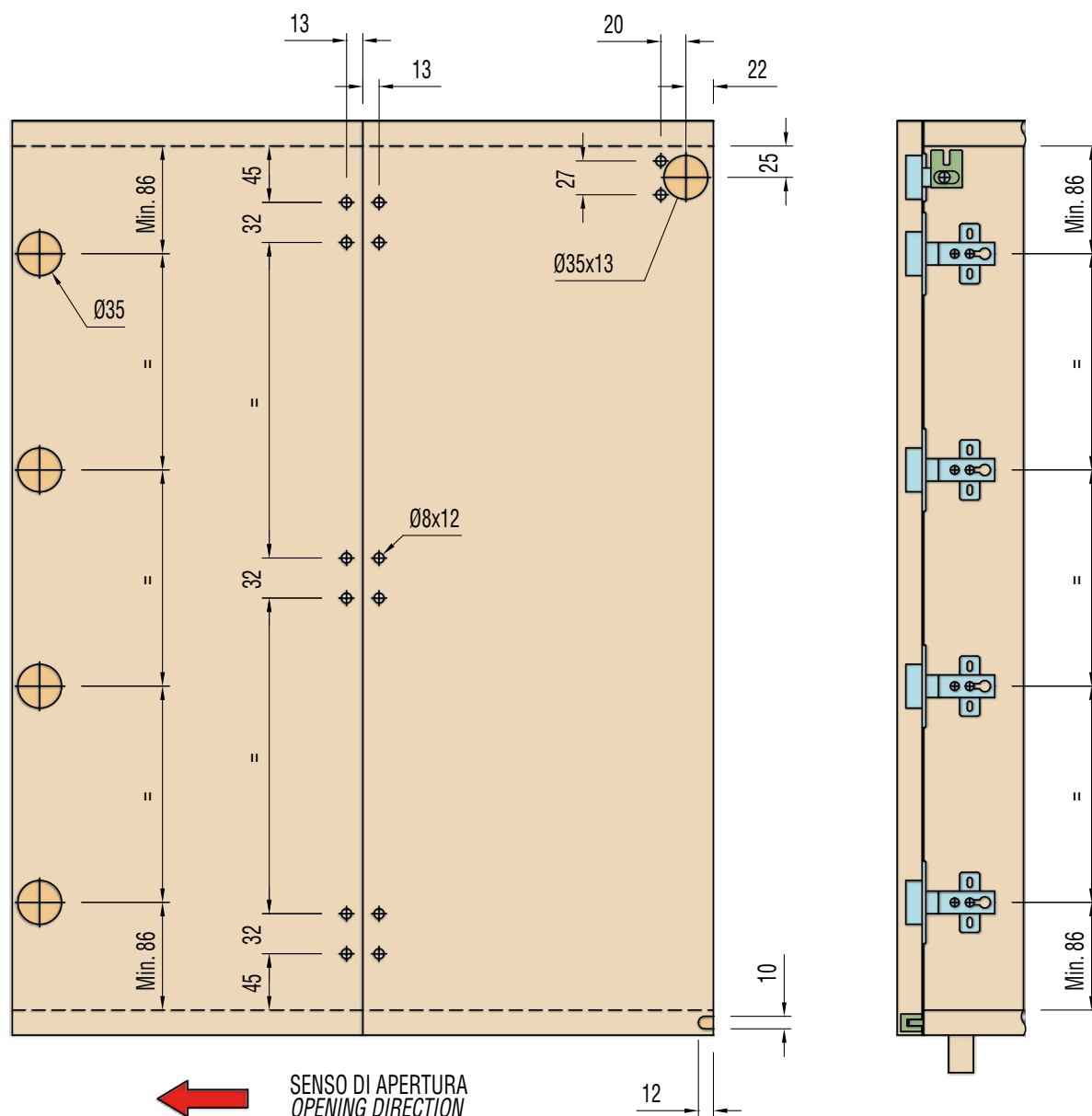

Il peso delle ante deve essere sostenuto dalle cerniere laterali montate sulla spalla del mobile e non dal carrello superiore, che ha la sola funzione di guida. Consultate il vostro fornitore per determinare quante cerniere devono essere montate sulla spalla del mobile, in funzione delle dimensioni e del peso delle vostre ante.

The weight of the doors is born by the side hinges fitted to the wardrobe side, not by the upper truck which only functions as a guide.

Turn to your supplier for the quantity of hinges which must be fitted to the wardrobe side, depending on the dimensions and weight of your doors.

Schema di montaggio / Assembling

SCHEMA MONTAGGIO

Inserire il carrello superiore (ART.0276-0277-0278-0279) nel binario superiore ART.0120.

Avvitare il binario sul top all'interno del mobile e successivamente fissare il carrello superiore all'apposita cerniera precedentemente montata sull'anta.

ASSEMBLING

Fit the upper truck (ART.0276-0277-0278-0279) into the upper profile ART.0120. Screw the profile onto the top, inside the wardrobe, and then fasten the upper truck to the corresponding hinge fitted to the door.

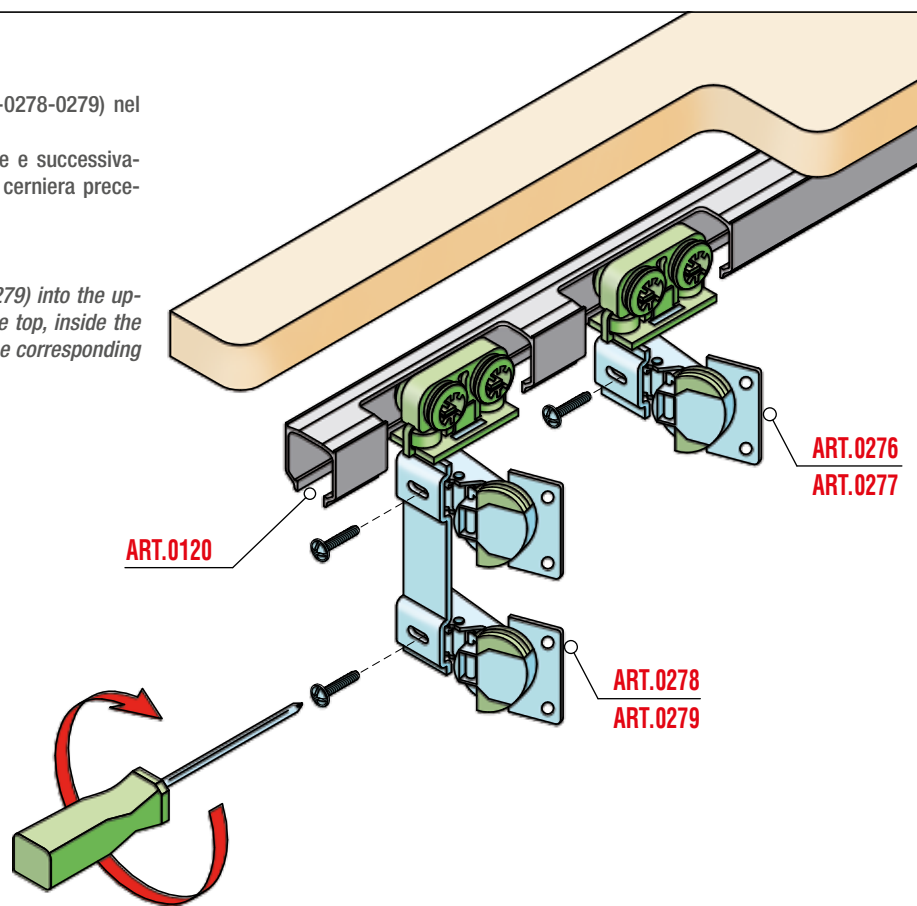

SCHEMA MONTAGGIO

Avvitare il profilo ART.0823 sulla base del mobile.

Tenere la guida ART.0827 nella corretta posizione sul profilo ART.0823 ed avvitare all'apposita cerniera precedentemente montata sull'anta.

ASSEMBLING

Screw the profile ART.0823 to the furniture base.

Hold the runner ART.0827 in the proper position on the profile ART.0823 and screw it to the hinge previously fitted to the door.

